

CT1 | 2 Spindles 1 Turret

Y-Axis Turret 76mm Built-in Spindle Double Spindle Versatility

- The CT1's double spindle design allows for the cutting of complex parts in a single setup, and coupled with a 16-station turret.
- When the Y-Axis turret is in the upper position, it can complete machining on parts in the main or sub spindle. In addition, tools can be placed facing either the main or sub spindle.
- The special structural design uses a 90° angle for the turret carriage so you maintain superb rigidity and stability in machining. Additionally, this allows you to use a simpler controller specification, reducing programming complexity and saving you money at the same time.
- The servo turrets are designed and built by CC Machinery especially for the CT series. This ensures maximum accuracy during machining, along with super fine finishes.



CT1

Machine Layout

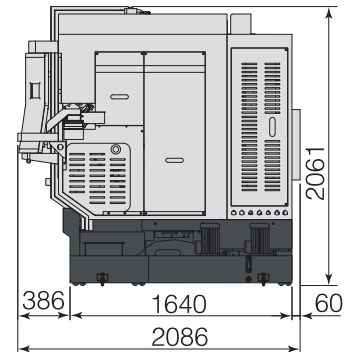
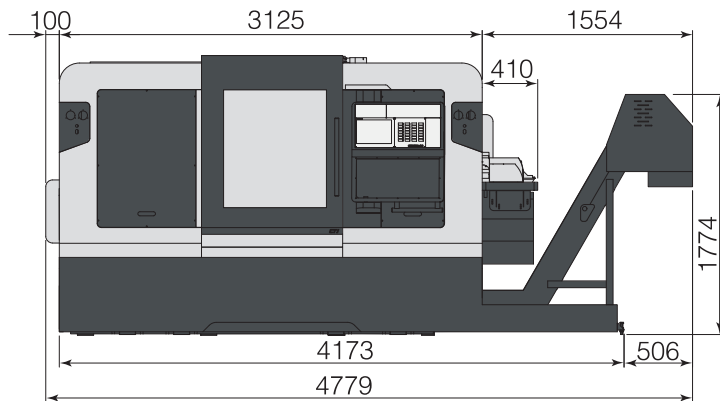

Unit: mm

Specifications

Model		CT1-76YM	CT1-76
Control Unit	Controller	MITSUBISHI / FANUC	
Capacity	Max. Turning Dia.	Ø325 mm	
	Standard Turning Dia.	Ø210 mm	
	Max. Turning Length	560mm	
Axes Specification	X1/Y1/Z1-Axis Travel	225 mm/±50 mm/636 mm	X1:225 / Z1:636 mm
	X1/Y1/Z1-Axis Motor	M: 2.2kw / F: 2.7kw	M: X1/Z1:2.2kw / F: X1/Z1:2.7 kw
	X1/Y1/Z1-Axis Rapid Travel Speed	16/6/40 m/min	X1:16 / Z1:40 m/min
	B-Axis Travel	690.5 mm	
	B-Axis Motor	M: 2.2 kw / F: 2.7kw	M: 2.2 kw / F: 2.7 kw
	B-Axis Rapid Travel Speed	40 m/min	
	Min. Input Unit	0.001 mm	
Spindle	Max. Bar Feeding Dia.	Ø76 mm	
	Spindle Motor	M: 15/22 kw / F: 18/22 kw	M: 15/22 kw / F: 18/22 kw
	Max. Spindle Speed	4000 rpm	
	Spindle Nose	A2-6	
Sub Spindle	Chuck Size	8"	
	Max. Bar Feeding Dia.	Ø65 mm	
	Spindle Motor	M: 7.5/11 kw / F: 18/22 kw	M: 7.5/11kw / F: 18/22 kw
	Max. Sub Spindle Speed	4000 rpm	
L, R, C	Spindle Nose	A2-6	
	Chuck Size	8"	
	Min. Moving Unit	0.001°	
Live Tooling Turret	C-Axis Rapid Travel Rate	600 min ⁻¹	
	O.D Turning Tool Size	□25 mm	
	I.D Turning Tool Size	Ø25 mm	
	Rotating Mode	Single Tool Transmission	—
Hydraulic	Live Tooling rpm	60~6000 min ⁻¹	
	Live Tooling Motor	3.7/5.5kw / 4.5 kw	
	Collet Size	ERØ32	
	Tool Holder & Tool Size	BMT65	—
Coolant Pump	Hydraulic Motor	5HP / 3.7 kw	
	Spindle Coolant Pump	1HP / 0.75 kw	
	Turret Coolant Motor	1HP / 0.75 kw	
	Chip Flush Pump	1HP / 0.75 kw	
	Sub Spindle Internal Coolant Pump	1HP / 0.75 kw	
Tank Capacity	Hydraulic Tank	45 L	
	Coolant Tank	325 L	
Machine	Voltage stabilizer / transformer	220V/45KVA	
	Machine Size (LxWxH) (includes chip conveyor)	4779 x 2086 x 2061 mm	
	Machine N.W. (includes chip conveyor)	8000 kg	

* Design and specs subject to change without notice.

* M: Mitsubishi, F: Fanuc

